



AURORA PUMP A member of PENTAIR PUMP GROUP

AURORA PUMP

BULLETIN 410/REV. P

410 SERIES SINGLE STAGE SPLIT CASE PUMPS

CAPACITIES TO 15000 G.P.M.
HEADS TO 500 FEET
TEMPERATURES TO 275° F

MODEL 412



MODEL 411

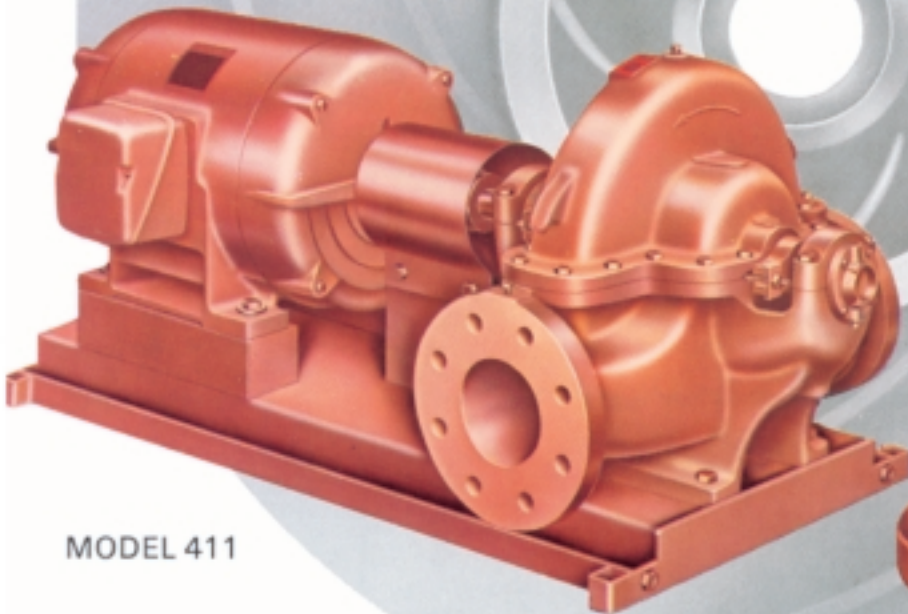

MODEL 413

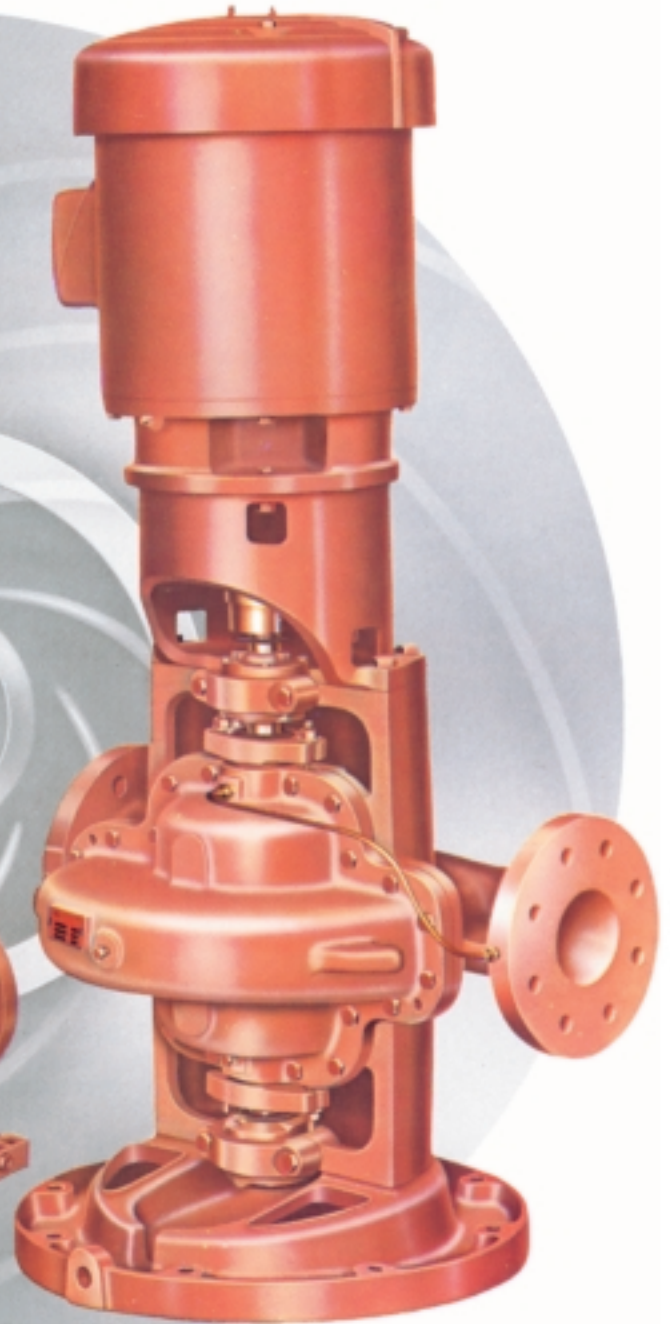

INTRODUCTION 410 SERIES PUMPS

The horizontal split case pump has long and properly been used for the handling of liquids where the utmost in reliability and accessibility are paramount. Billions of gallons of liquid have been pumped by split case double suction pumps and billions more will be pumped con-

sidering the rapid industrial, agricultural and commercial expansion. The Aurora 410 Series pumps make a significant contribution to the customer requirements for pumps on this type of service. The 410 Series is a modern design based on Aurora Pump's 50 years experi-

ence with the design, sales and manufacture of horizontal split case pumps. Look through this bulletin and see what real accomplishments can be made when an imaginative approach is taken to the customer's problem of moving liquids within a piping system. See Aurora now!



**STANDARD
RIGHT HAND ROTATION**



**OPTIONAL DUAL DRIVE
RIGHT HAND ROTATION**

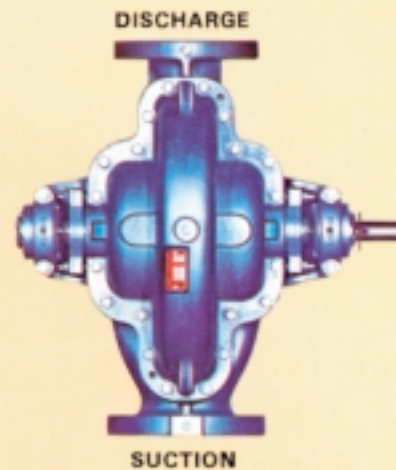

**OPTIONAL
LEFT HAND ROTATION**

QUICK REFERENCE 410 SERIES FEATURE SELECTOR

STANDARD

- Bronze fitted pump construction
- Bronze shaft sleeves
- Dynamically balanced impellers
- Bronze case wearing rings
- Twin volute on 10" and larger pumps
- Stainless steel impeller key
- Regreasable ball bearings
- Single row ball bearing (inboard)
- Double row ball bearing (outboard)
- Mechanical seals . . . single unbalanced (Model 412 and 413)
- Graphite and TFE lubricated acrylic packing
- Internal bypass between casing and stuffing box
- 125# ASA flanges
- 250 psi case working pressure
- Carbon steel shaft
- Stuffing box bushings
- Lifting lugs
- Hydrostatic test
- Cast integral bearing arms
- Water slingers and grease seals
- External bypass between casing and stuffing box (Model 412 and 413)
- Coupling guard (Model 411)

OPTIONAL

- All iron, all bronze or special alloy pump construction
- Hardened 440C stainless steel shaft sleeves (packing only)
- 316 stainless steel shaft sleeves (mechanical seal)
- Impeller wearing rings
- Oil lubricated ball bearings (Model 411 horizontal pump)
- Mechanical seals . . . single unbalanced (Model 411)
- . . . single balanced (All Models)
- Stainless steel or monel shaft
- External bypass between casing and stuffing box (Model 411)
- Steel drip rim, formed steel or fabricated steel bases
- Double extended shaft (Model 411)
- Right or left hand rotation
- Certified performance test
- Packing with lantern ring (Model 411)
- 250# ASA suction and discharge flanges
- Bottom suction or chair mounted pumps
- Water cooled cartridge caps

VERTICAL PUMP FEATURES

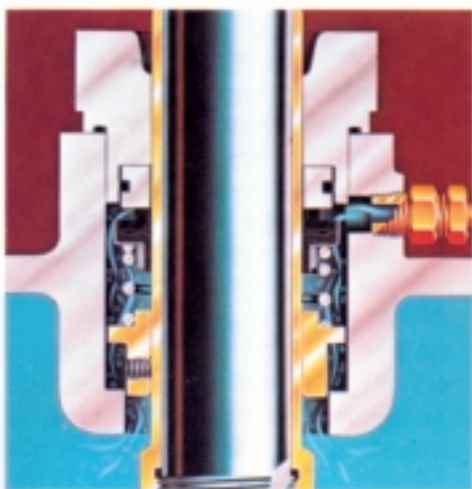

EXTERNAL UPPER SEAL FLUSH



INLINE PIPING IN ANY DIRECTION

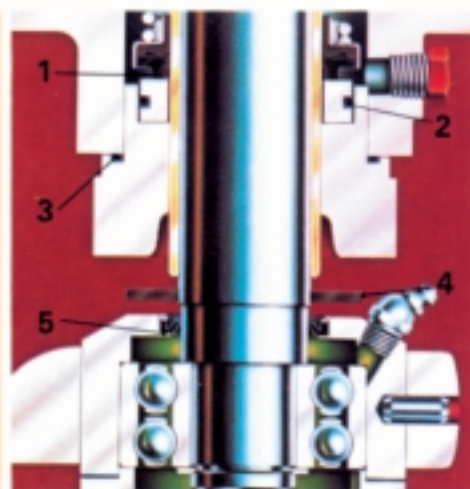

FIVE WAY BEARING PROTECTION

GO VERTICAL AND PUT 2 PUMPS WHERE ONLY ONE HORIZONTAL WOULD FIT.

Aurora's space saving vertical split case pumps have long been recognized for their reliability. This reputation in the field of vertical installations has been re-emphasized since the introduction of the Model 413 as pumps of unmatched quality. VERTICAL PUMPS PROVIDE DISTINCT ADVANTAGES OVER HORIZONTAL PUMP CONSTRUCTION.

- A. Less floor space required.
- B. Inline piping arrangement al-

lows piping in any direction. C. Elevated motor protects against potential flooding if the pump station is in a low area.

Additional features described for the horizontal pumps are also found in the vertical pumps. In addition, there are several features unique only to Model 413.

1 COUPLING ALIGNMENT True alignment is vital to long life and proper performance. To maintain proper coupling alignment the mounting bracket is rabbet fitted to the motor.

2 MECHANICAL SEALS Standard construction includes car-

bon against Ni-Resist face for optimum hot water performance. Long life is also assured with 303 stainless steel metal parts and "Buna-N" elastomers. **3 BEARING PROTECTION** Grease seals and water slingers are provided to protect the bearings from contamination. This important feature is also standard on horizontal pumps.

4 CAST IRON DRIP RIM BASE Accurate positioning of the pump is assured by the mounting base. A drip rim is incorporated in the base design to control condensation and leakage.

VERTICAL MODEL 413 STANDARD RIGHT HAND ROTATION

VERTICAL MODEL 412 OPTIONAL LEFT HAND ROTATION

SPACE SAVING VERTICAL SPLIT CASE PUMPS — PUT MOTOR ABOVE FLOOD CONDITIONS

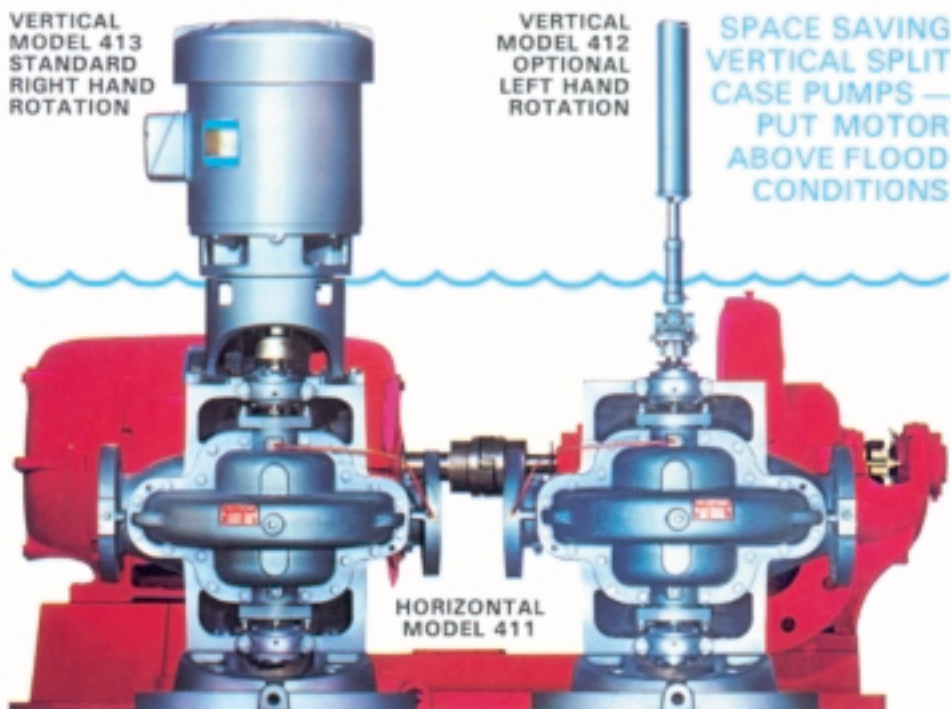

MODELS 411 are horizontally baseplate mounted with a driver flexibly coupled to the pump. This design is recommended where floor space is readily available and where flooding of the installation is not possible. MODELS 412 are vertically mounted and utilize flexible shafting between the driver and the pump. This model is frequently used on difficult applications where flooding of the installation is a possibility. MODELS 413 are vertically mounted with an elevated driver coupled directly to the pump thru a flexible coupling. Model 413 is very popular for installations where available floor space is limited and where possible flooding is marginal.

VERTICAL PUMPS

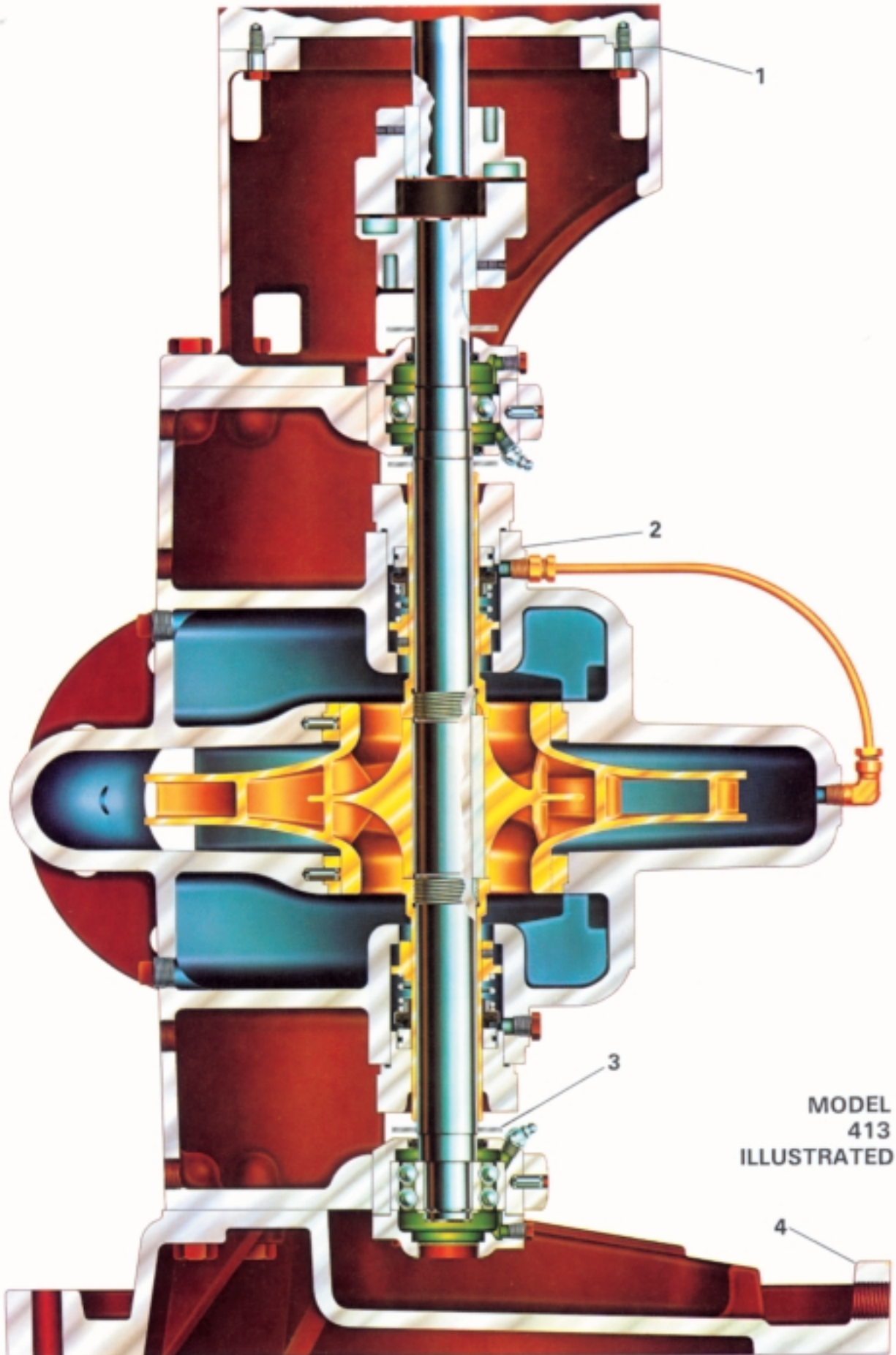

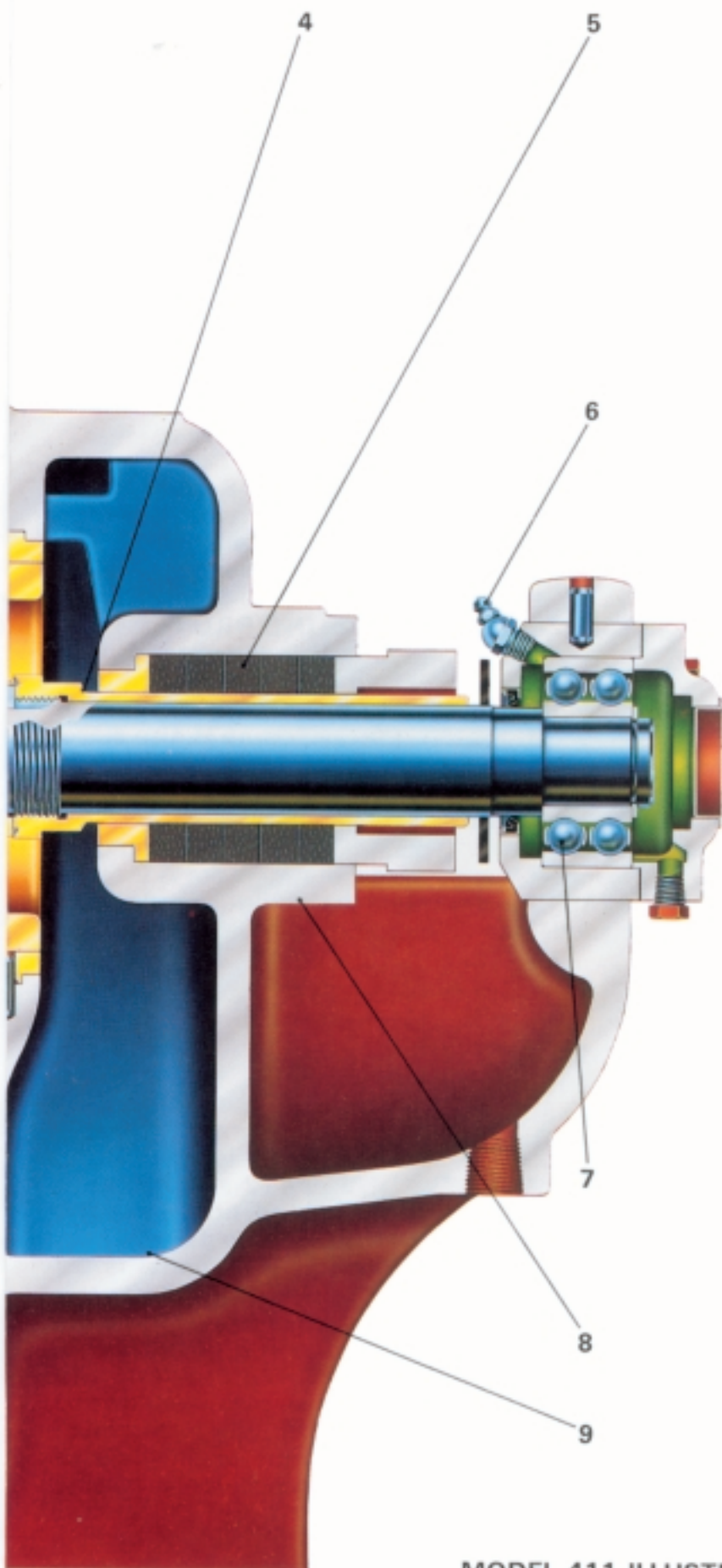

4 BRONZE SHAFT SLEEVE prevents shaft wear, is slip fit over the shaft, keylocked, and extends the entire length of each stuffing box. Shaft sleeves and impeller are "O" ring sealed to eliminate corrosion of the shaft by the pumped liquid. This eliminates the need for high cost, special stainless steel or monel shafts.

5 INTERCHANGEABLE STUFFING BOX for mechanical seals or packing. Packing is standard on horizontal pumps. Optional lantern rings have internal water seal passages between the casing and stuffing box and cannot be damaged. Mechanical seals have carbon against Ni-Resist face. Long life is assured with 303 stainless steel metal parts and "Buna-N" elastomers. Several optional mechanical seals are available.

6 GREASE LUBRICATION purges old grease from bearings. Oil lubrication is optional on horizontal pumps. Lube fittings are conveniently located for quick accessibility and provide positive bearing lubrication. Oil seals and non-sparking Neoprene rotating slingers protect both bearings during pump operation and washdowns.

7 BEARINGS selected for 50,000 hour minimum life at maximum load. Average bearing life 5 x minimum. Double row thrust ball bearing is standard on all models. Short bearing span holds shaft deflection to .002" at face of stuffing box at maximum load. Integral bearing arms eliminate bearing misalignment and simplify service.

8 LEFT HAND ROTATION can be readily provided with standard parts. Tandem drive pumps require only a different shaft.

9 CERTIFIED PERFORMANCE with **POSITIVE SUCTION PRESSURE** or with a **SUCTION LIFT** are available on each pump for customer approval. Pumps are all hydrostatically tested.

MODEL 411 ILLUSTRATED

RANGE CHARTS 1150 R.P.M.

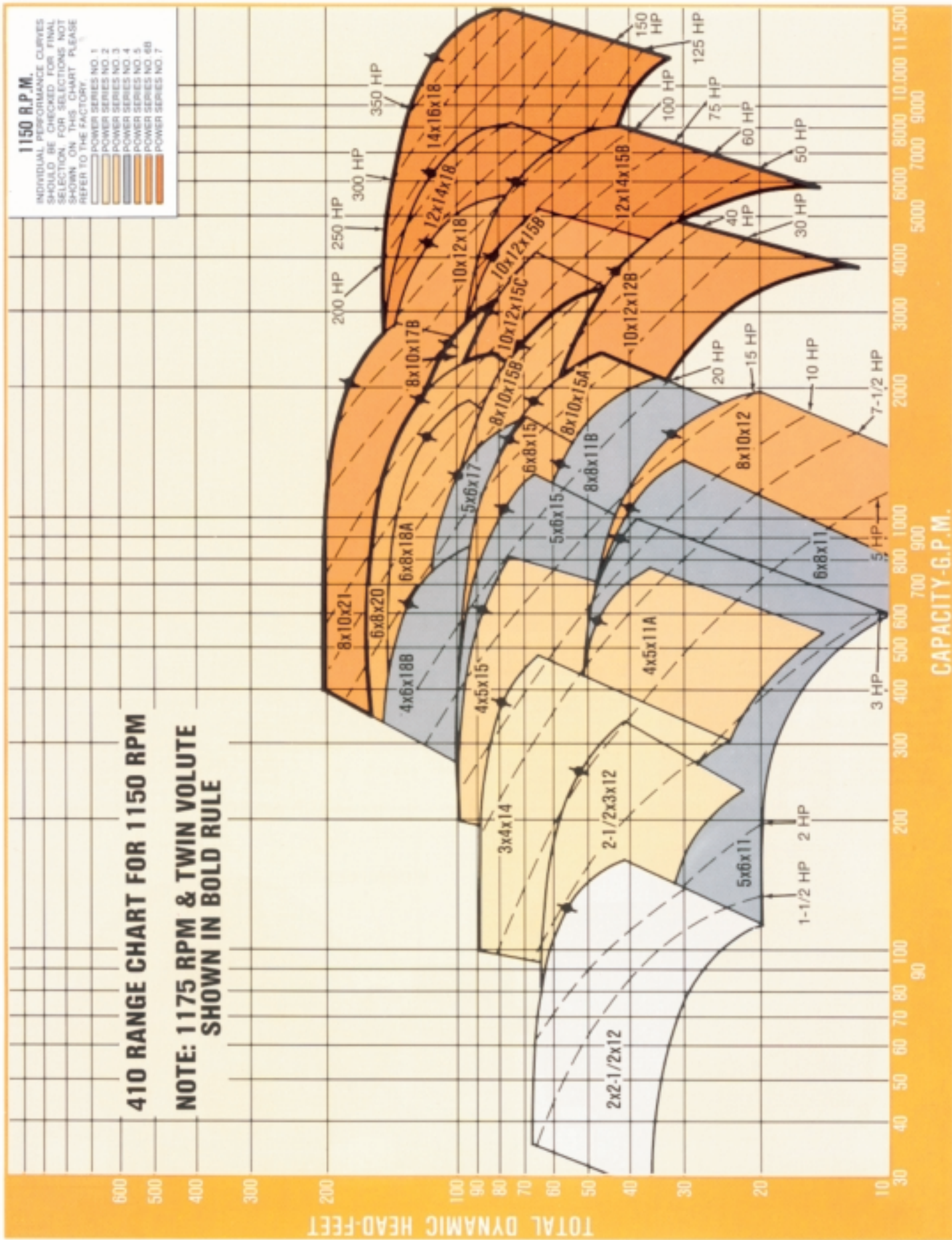

1750 R.P.M.

INDIVIDUAL PERFORMANCE CURVES SHOULD BE CHECKED FOR FINAL SELECTION. FOR SELECTIONS NOT SHOWN ON THIS CHART PLEASE REFER TO THE FACTORY.

- POWER SERIES NO. 1
- POWER SERIES NO. 2
- POWER SERIES NO. 3
- POWER SERIES NO. 4
- POWER SERIES NO. 5
- POWER SERIES NO. 6B
- POWER SERIES NO. 7

410 RANGE CHART FOR 1750 RPM

NOTE: 1775 RPM & TWIN VOLUTE SHOWN IN BOLD RULE

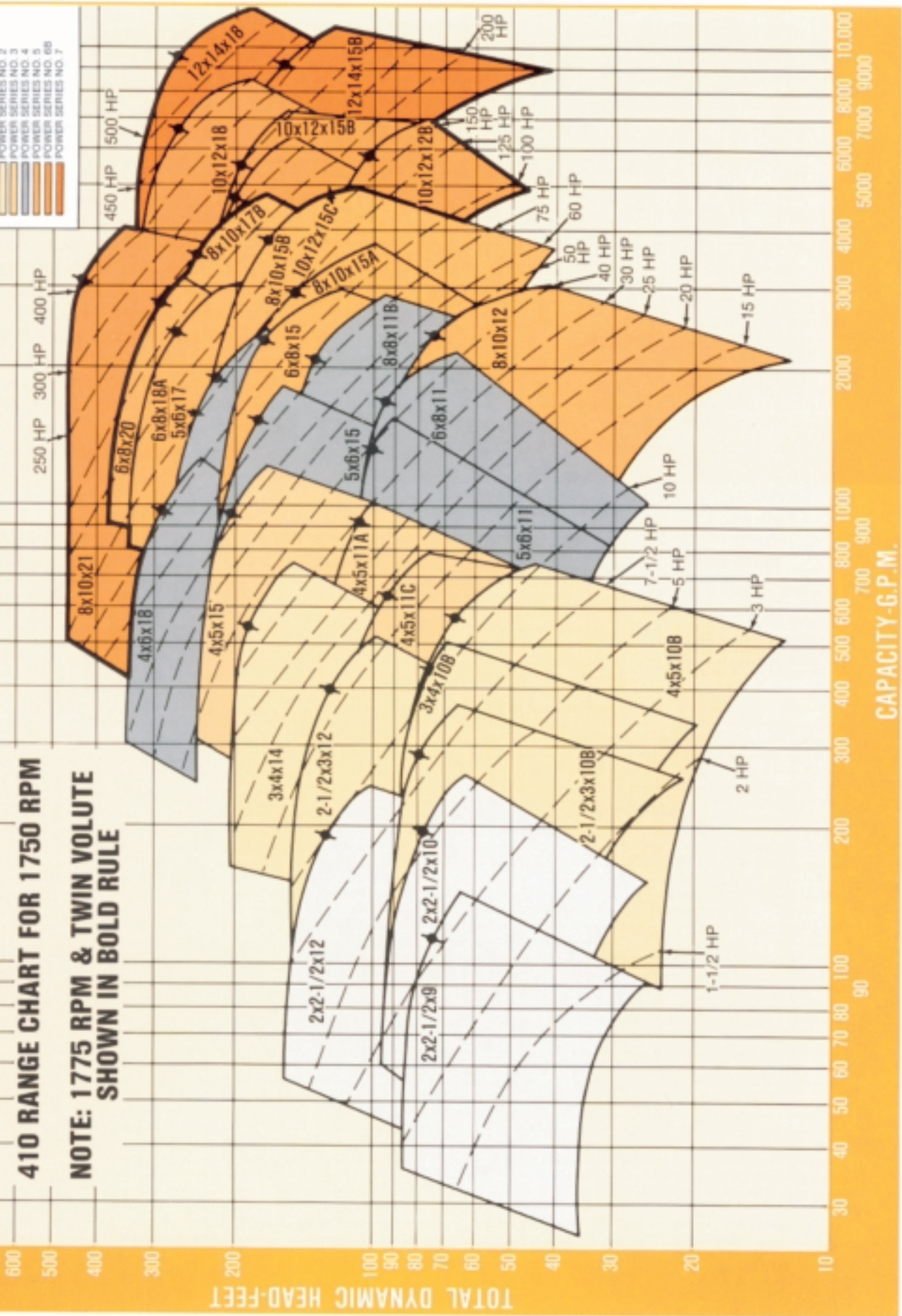

SINGLE VOLUTE 3500 R.P.M.

PERFORMANCE CURVES

The individual curve for the size pump selected is found in catalog section 410. These performance curves give complete operating characteristics, efficiency, horsepower, and N.P.S.H. required. Horsepower lines on these curves are based on specific gravity of 1.0. To obtain the horsepower for a liquid of a different specific gravity, multiply the horsepower obtained from the curve by the specific gravity of that liquid. The performance curve illustrated to the left is typical of the individual curves readily available for each pump size.

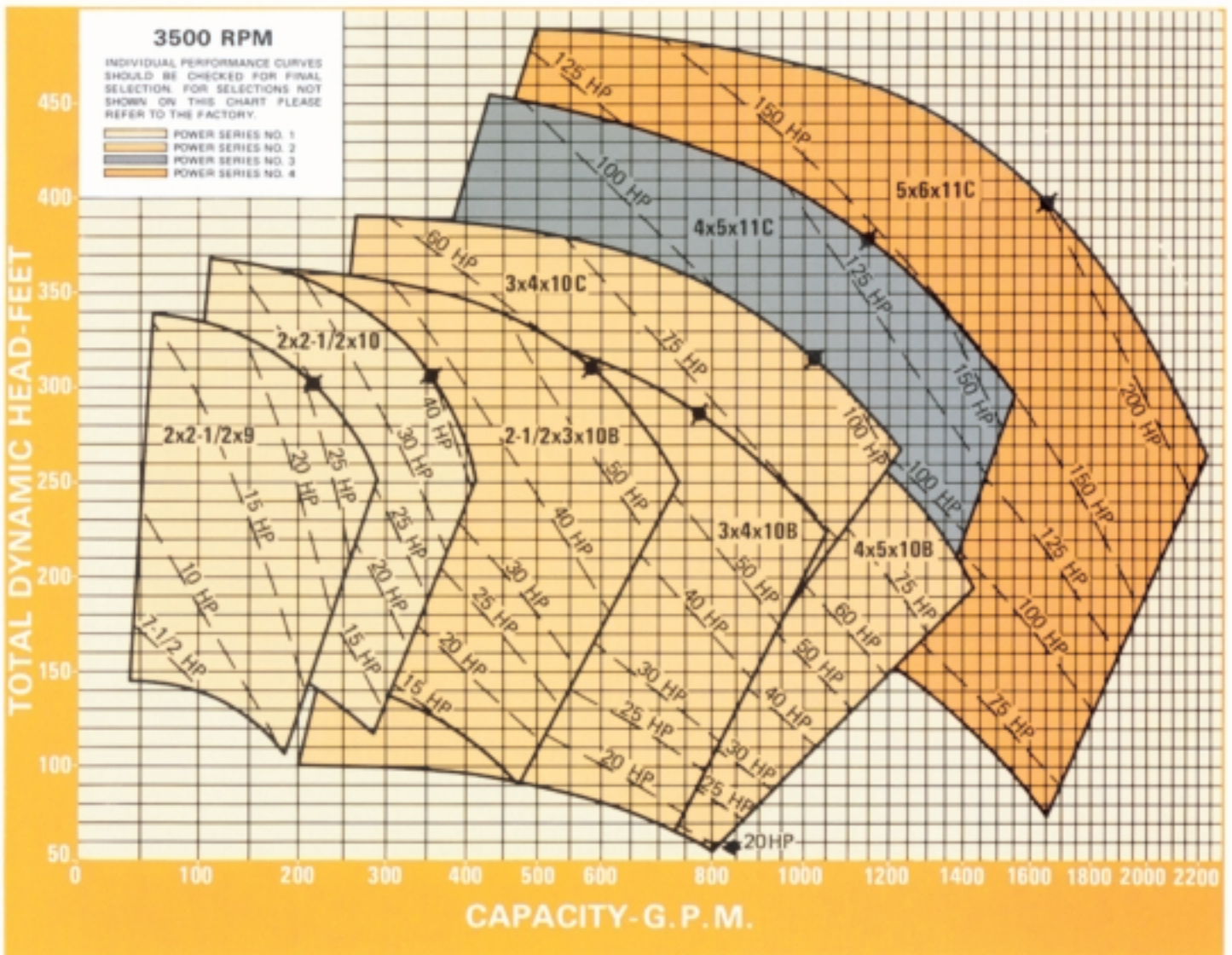
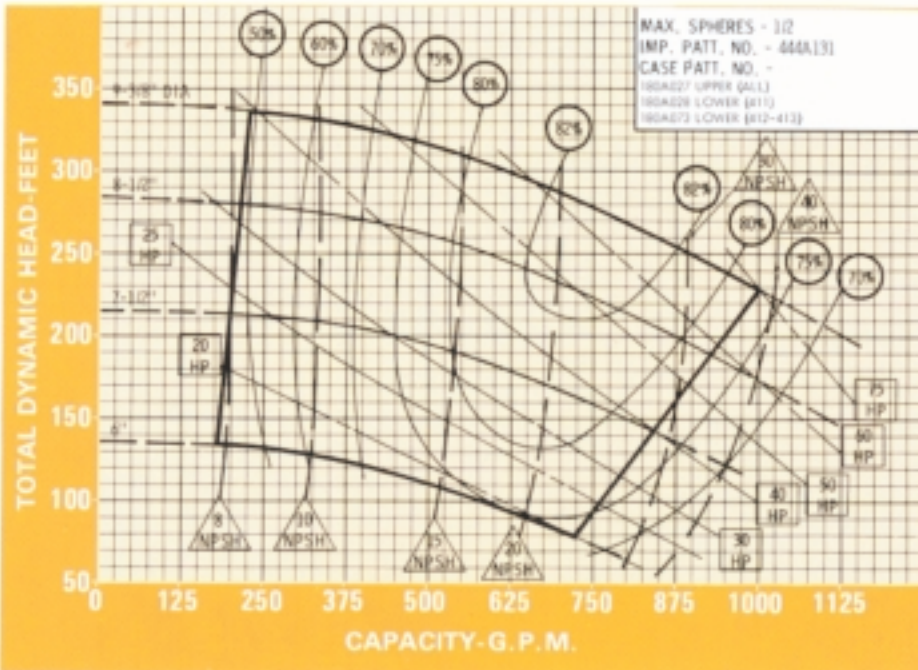

HORIZONTAL PUMP DIMENSIONS

MOTOR FRAME	MODEL 413	143 HP	145 HP	182 HP	184 HP	213 HP	215 HP	254 HP	256 HP	284 RPH	286 RPH	324 HP	326 HP	364 HP	365 HP	404 HP	405 HP	444 HP	445 HP												
	MODEL 411	143 T	145 T	182 T	184 T	213 T	215 T	254 T	256 T	284 TS	286 TS	324 TS	326 TS	364 TS	365 TS	404 TS	405 TS	444 TS	445 TS												
HORSE POWER	3500 RPM	1½	2-3	5	7½	10	15	20	25	30	—	40	—	50	—	60	—	75	—	100	—	125	—	150	—	200†	—	—	—		
	1750 RPM	1	1½	3	5	7½	10	15	20	—	25	—	30	—	40	—	50	60	—	75	—	100	—	125	—	150	—	200†	—		
	1150 RPM	—	1	1½	2	3	5	7½	10	—	15	—	20	—	25	—	30	—	40	—	50	—	60	—	75	—	100	—	125		
MOTOR WEIGHT	MODEL 411	40	45	72	80	130	145	220	240	330	330	370	370	475	475	525	525	630	630	690	690	830	830	915	915	1095	1095	1270	1270		
	MODEL 413	43	48	84	102	132	156	300	300	420	420	420	420	570	570	570	570	950	950	950	950	1230	1230	1230	1230	1680	1680	1680	1680		
C		12	13	13	14	16	18	21	23	22	24	24	25	25	26	26	28	27	29	28	30	30	33	31	34	34	38	36	40		
D (SEE NOTE **)		3½	3½	4½	4½	5¼	5¼	6¼	6¼	7	7	7	7	8	8	8	8	9	9	9	9	10	10	10	10	11	11	11	11		
P APPROX.		8	8	10	10	11	11	13	13	16	16	16	16	18	18	18	18	20	20	20	20	22	22	22	22	26	26	26	26		
AG APPROX.		11	12	14	15	16	17	20	21	22	22	23	23	25	25	26	26	25	25	25	25	28	28	28	28	32	32	32	32		
MODEL 411 BASE NUMBER																															
POWER SERIES MODEL 411	1	3	3	3	3	3	3	8	8	8*	—	8*	—	11*																	
	2	3	3*	3*	3*	5	5	8	8	9	9	9	9	11*	12	11*	12	12	—	12											
	3				5*	8	8	8	9	11	11	11	11	12	12	12	12	12	—	12	—	15*	—	15*							
	4				6*	6*	9	9*	—	11	—	11	11	11	12	12	12*	12*	12*	16*	—	16*	—	16*	—	16*	—	16*	—	16*	
	5							11	11	—	12	—	12	—	12*	—	12	12	12	13	13	16	16*	16*	16*	16*	16*	16*	16*	—	
	6B												13	—	13*	—	13*	—	13*	13*	13*	17	17*	17	17	17	17	17	17	18	
	7																					17*	—	17*	17*	18	18	18	18*		
BASE		3	5	6	8	9	11	12	13	15	16	17	18	FLANGES — ASA STD.				FURNISHED AS:													
BASE WEIGHT		49	59	68	96	109	164	192	235	291	344	399	441	250# WITH 125# DRILLING				STANDARD													
HA		15	17¼	17¼	20%	20%	26%	26%	26%	30%	30%	30%	30%	250# WITH 250# DRILLING				OPTIONAL													
HB		33%	36%	42%	42%	48%	46%	54%	64%	54%	64%	74%	82%																		
HN		3	3	3	3	3	4	4	4	4%	4%	4%	4%																		

NOTES Apply to all Models.

*Add 1" for true discharge centerline.

**Always use largest of 2 "D" dimensions.

†May not be used for all pump sizes in this power series. Consult individual dimension pages for final selection.

‡For motor and baseplate dimensions over 200 HP refer to the factory.

§These pump sizes are available in a vertical chair mount configuration in Models 412C and 413C. See individual dimension pages for complete dimensions and weights.

1. Dimensions and weights are approximate.

2. Complete dimensions are available.

3. Not for construction purposes unless certified for approval.

4. Frame sizes shown are for open drip proof motors only.

5. Add pump, base and motor weight for unit total weight.

6. Conduit box is shown in approximate position. Dimensions are not specified as they vary with each motor manufacturer.

7. Aurora Pump reserves the right to make revisions to its products and their specifications, and to this bulletin and related information without notice.

8. 10 x 12 x 18 and 12 x 14 x 15 pump sizes are also available as bottom suction horizontal Model 411B pumps. See individual dimension pages for complete dimensions.

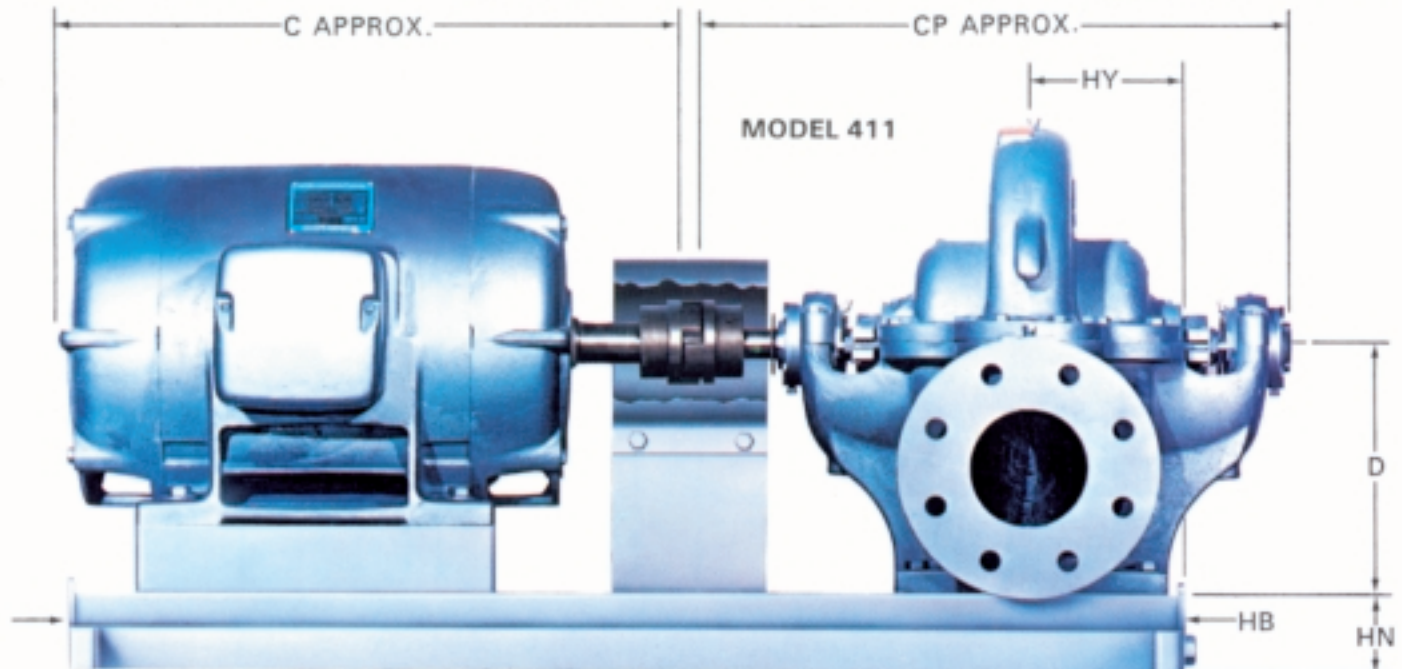

VERTICAL PUMP DIMENSIONS

PUMP SIZE			P. SERIES	PUMP WGT. (LBS.)		A	D**	S	X	CP	HY	VE	YY
DISCH	SUCT	BORE		411	413								
2	2 1/2	9	1	145	215	18	7	3 1/2	8 1/2	21	4 1/2	11 1/2	9
2	2 1/2	10		145	215	18	7	3 1/2	8 1/2	21	4 1/2	11 1/2	9
2	2 1/2	12	2	175	260	18	8	4	10	21	4 1/2	11 1/2	10 1/2
2 1/2	3	10		215	300	18	8	4	9 1/2	24	5 1/2	13	10
2 1/2	3	12	3	255	360	18	9	4 1/2	11	24	5 1/2	13	11 1/2
3	4	10		260	365	18	9	4 1/2	10	24	5 1/2	13	11
3	4	14	4	310	435	18	10	5	12	24	5 1/2	13	13
4	5	10		330	465	18	9	4 1/2	10	24	5 1/2	13	11 1/2
4	5	11	5	390	435	22	10	5	11 1/2	26	6 1/2	14	12 1/2
4	5	15		415	490	22	11	5 1/2	13	26	6 1/2	14	14
4	6	18	6	560	780	22	12 1/2	6 1/4	14	29	6 1/2	15	16
5	6	11		455	580	22	11	5 1/2	11 1/2	29	6 1/2	15	13 1/2
5	6	15	7	530	735	22	12 1/2	6 1/4	13 1/2	29	6 1/2	15	15
5	6	17		635	855	22	12 1/2	6 1/4	14	29	6 1/2	15	15
6	8	11	8	520	650	22	12 1/2	6 1/4	13 1/2	29	6 1/2	15	14 1/2
8	8	11		605	835	22	12 1/2	6 1/4	12	29	6 1/2	15	14 1/2
6	8	15	9	585	735	30	13 1/2	6 1/2	14 1/2	32	7 1/2	17	16 1/2
6	8	18		890	1020	30	14 1/2	8	16	32	7 1/2	17	18
6	8	20	10	875	1095	30	14 1/2	8	15 1/2	32	7 1/2	17	18
8	10	12		740	925	30	14 1/2	8*	17	32	7 1/2	17	17 1/2
8	10	15	11	835	1040	30	14 1/2	8*	17	32	7 1/2	17	17 1/2
8	10	17		865	1085	30	14 1/2	8	17	32	7 1/2	17	17 1/2
8	10	21	12	955	1111	18 1/2	9 1/2	18	38	11 1/2	—	21	
10	12	12		1325	1575	40	23	12	16	38	11 1/2	—	19
10	12	15	13	1390	1111	25	13 1/2	17	38	11 1/2	—	20	
10	12	18		1725	1111	25	13 1/2	18	38	11 1/2	—	22	
12	14	15	14	2000	1111	24	15	17	44	11 1/2	—	22	
12	14	18		2100	1111	24	15	18	44	—	—	—	23
14	16	18	2850	1111	29 1/4	16	22	44	—	—	—	27	

MODEL 412 AND 413					
POWER SERIES	1	2	3	4	5
UP TO 256 HP	26	30	33	35	—
284 HP & UP	28	32	35	37	41
CP ₁	23	27	29	31	35

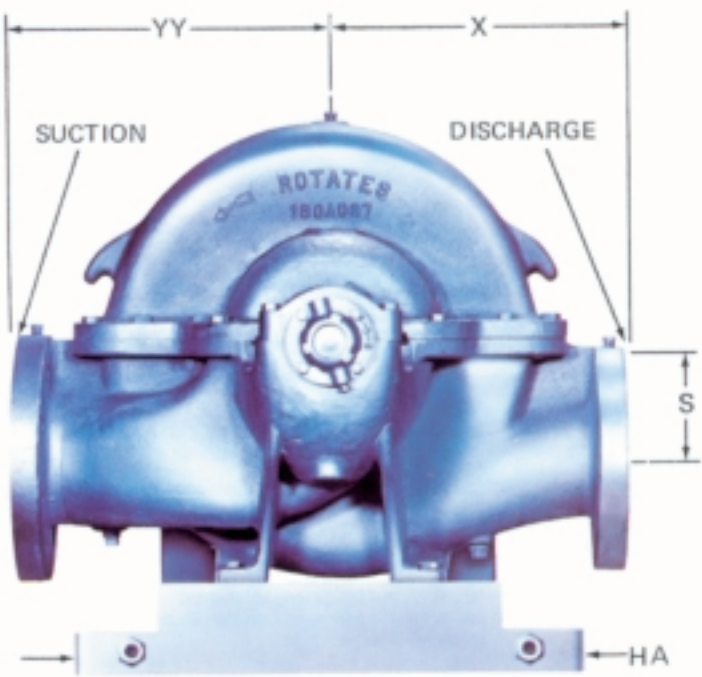
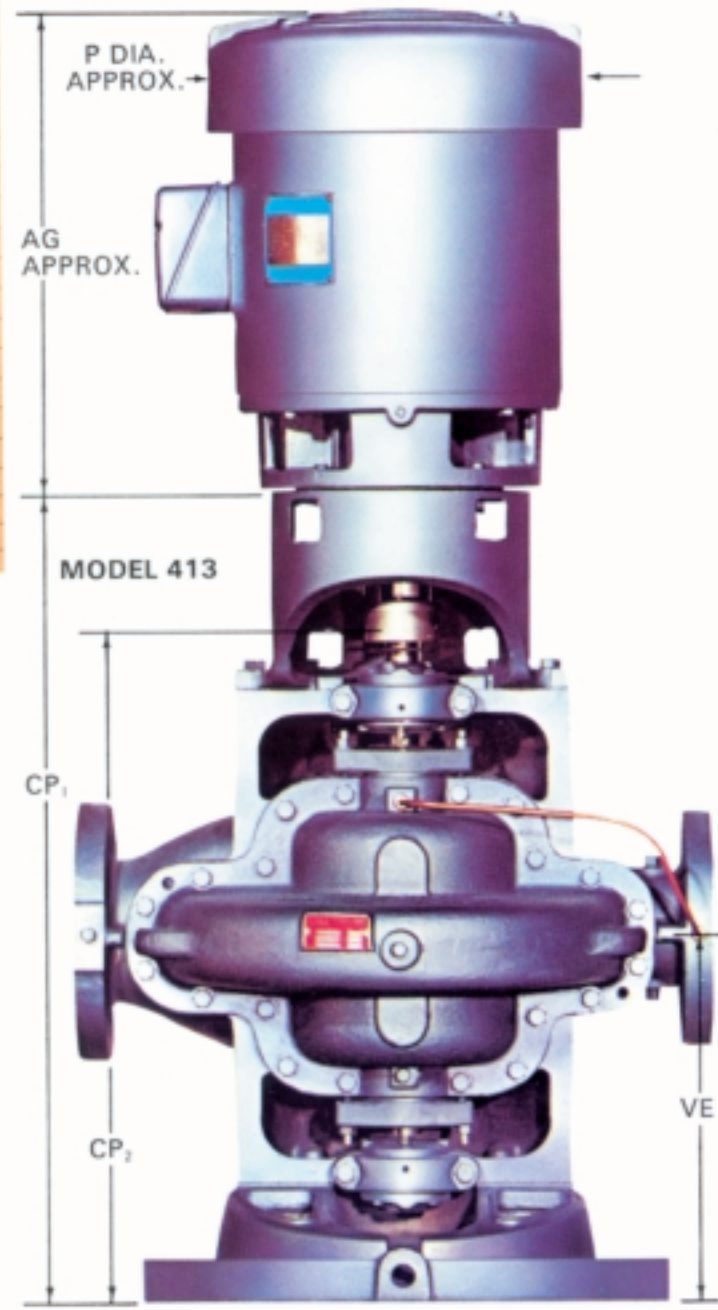
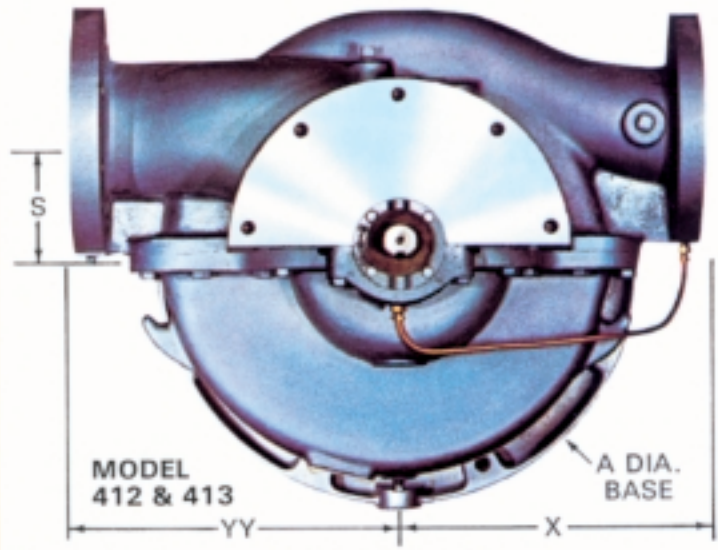

ENGINEERING SPECIFICATIONS

MODEL 411-412 AND 413 SPLIT CASE BASE MOUNTED

Furnish and install as shown on the plans Right hand (Left hand) Aurora Model (Horizontal-411) (Vertical-412 Open Shaft) (Vertical-413 Flexible Coupled) type Split-Case, Double Suction, Single Stage centrifugal pump, Size x x of bronze fitted (all bronze) (all iron) (stainless steel) construction. The pump shall be capable of delivering at design conditions a capacity of G.P.M. when operating against a Total Dynamic Head of feet, with a temperature of °F, specific gravity Pump shall have minimum guaranteed efficiency at design capacity of %. Pump must also be capable of delivering a maximum of G.P.M. when operating against a head of feet, and at this condition shall have a minimum efficiency of %. Minimum shut off head acceptable will be feet. Pump shall operate at a maximum synchronous speed of R.P.M. A unit operating at a lesser rotative speed will be considered, but in no-event will a pump operating at more than the maximum speed specified be acceptable. The pump casing halves shall be of the inline piping design and will be constructed of "CLASS 30 CAST IRON," C.I. having a minimum tensile strength of 30,000 psi, and shall be of sufficient thickness to withstand stresses and strains at full operating pressures. Casings shall be subject to a hydrostatic pressure test at 150% of the specified duty point. Bearing housing supports, suction and discharge flanges shall be integrally cast with the lower half of the casing. Removal of the upper half of the casing must allow the rotating element to be removed without disconnecting the suction and discharge flanges. The upper casing is to be dowel aligned to the lower casing. Pump sizes 10" and larger are to be of the twin volute design. Drain openings must be provided in the bearing arms for removal of lubricating liquid. Impeller shall be of the enclosed

double suction type and shall be of precision cast bronze (or optional material). Impeller shall be dynamically balanced and securely fastened to the shaft by key and screw locked shaft sleeves. The vanes shall be designed to reduce noise. The pump shaft shall be made of high grade SAE 1045 Steel or equal, accurately machined to give a true running rotating element. The minimum dia. acceptable will be ". The shaft shall be protected from wear by bronze (.) sleeves which are key locked and threaded so that the sleeves tighten with the rotation of the shaft. Buna o-rings must be provided between the impeller hub and the shaft sleeves to prevent pumped liquid from corroding the shaft. Pump shall be equipped with easily renewable bronze (.) casing rings (impeller wearing rings) so designed that hydraulic pressure will seat them against a shoulder in the pump case around the full periphery of the wearing ring. The wear rings will be locked in place by doweeling to prevent rotation. The rotating element shall be mounted in heavy duty grease lubricated ball bearings and shall be equipped with water stingers on side next to pump glands. Bearing housings shall be so designed to flush lubricant through and provide continuous cleaning of bearing surfaces and maximum protection against overheating. The pump shall be supplied with a single row inboard bearing primarily for radial loads and a double row outboard bearing primarily for thrust loads. Both bearings shall be regreaseable lubrication ball type, designed for 250,000 hours average life. Each bearing shall be mounted in a machined housing that is moisture and dust proof. The housing shall have registered fits to assure alignment, pinned to prevent rotation, and bolted to the bearing arms. Each housing shall be supplied with a grease fitting and a plugged relief port. **MODEL 411** - Stuffing boxes shall be placed on both sides of the pump centerline to seal the pump shaft. All packed pumps having a suction lift shall be provided with lantern rings connected to the pressure side of the pump by cored passages in

the parting flange of the pump. The stuffing boxes shall be equipped with heavy, cast, split glands with extra length, for easy removal for packing inspection and maintenance. Pump and motor shall be mounted on a common heavy base plate of (steel with drip rim) (formed steel) (structural steel). Pump and motor must be checked for alignment after the pump base has been installed and grouted in place, in accordance with the standards of the Hydraulic Institute. There shall be no strain transmitted to the pumps. **MODEL 412 and 413** - Mechanical seal boxes shall be placed on both sides of the pump centerline to seal the pump shaft. Each pump is to be furnished with mech. seals with all metal parts to be 303 stainless steel with "Buna-N" elastomers, Ni-Resist seat, and carbon washer. A bypass line must be provided for the upper seal between the seal faces and the discharge flange to assure adequate venting of the seal chamber and to provide lubrication. All pumps shall be provided with cored passages in the parting flange of the pump to provide additional circulation to both seals. The mech. seal boxes shall be equipped with heavy, cast, one piece "O" ring sealed glands. The pump shall be supported by a cast iron drip rim base. **MODEL 412** - Vertical open shaft pumps are to be driven through flexible shafting with dia. tubing, and, intermediate bearings. Shafting must be of sufficient size to transmit required H.P. and must be provided with a slip spline which will permit removal of the pump rotating assembly without removing any section of intermediate shafting, bearings, suction or discharge piping. **MODEL 413** - Vertical flexible coupled pumps shall be furnished with a cast iron motor bracket which is to be bolted to the vertical casing. The motor bracket must be machined with a register fit to ensure proper alignment of motor and pump shaft. **MODEL 411 AND 413** - The pumps shall be flexible coupled to a standard (horizontal) (vertical) NEMA HP phase Hertz volts RPM (drip-proof) (tot. encl.) (explosion-proof) motor.

NOTE: Aurora Pump reserves the right to make revisions to its products and their specifications, and to this bulletin and related information, without notice.

— Your Authorized Local Distributor —



ap AURORA
Pentair Pump Group

MARKETING & SALES:

800 AIRPORT ROAD • NORTH AURORA, ILLINOIS U.S.A. • 60542
PHONE: (630) 859-7000 U.S.A./CANADA FAX: (630) 859-7060
WORLDWIDE FAX: (630) 859-1226

WEB: www.aurorapump.com

EMAIL: aurora_info@pentairpump.com

AURORA MFG. PLANT:

800 AIRPORT ROAD • NORTH AURORA, ILLINOIS U.S.A. • 60542

SALES OFFICES IN ALL MAJOR CITIES AND COUNTRIES

Refer to "Pumps" in yellow pages of your phone directory for your local Distributor.